

COLLEZIONE “ARGENTO - E 193”

UNDERMOUNTED ROUND BOWLS

BACS RONDS SOUS LE PLAN

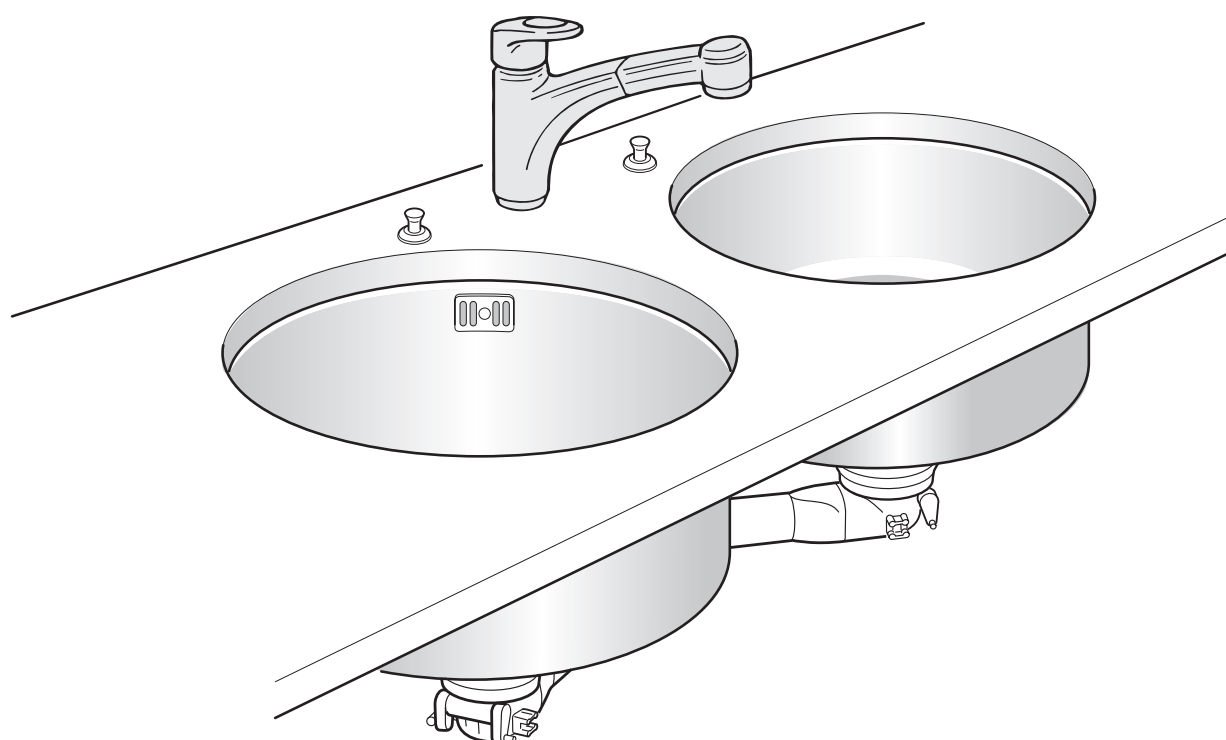

INSTALLATION GUIDE
GUIDE POUR L'INSTALLATION

BOWL DIMENSIONS (cm)
DIMENSIONS DES BACS (cm)

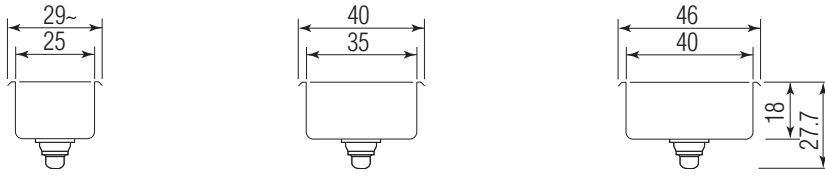

Control knob on right-hand side
Poignée de commande à droite



VDS 25

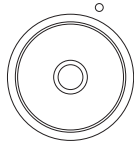

VS 35

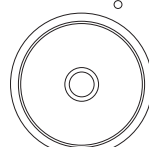

VS 40

Control knob on left-hand side
Poignée de commande à gauche

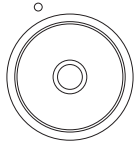

VS 35

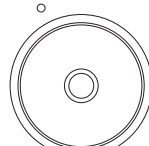

VS 40

BOWL INSTALLATION CUTOUT DIMENSIONS (cm)
DIMENSIONS DES TROUS DES BACS (cm)

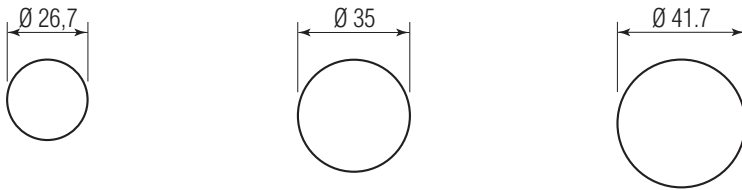

Control knob cutout
Trou poignée de commande



DIMENSIONS AND POSITION OF CONTROL KNOB AND TAP INSTALLATION CUTOUTS (cm)
DIMENSIONS ET POSITIONS DES TROUS DE LA POIGNÉE DE COMMANDE ET DU ROBINET (cm)

STANDARD POSITION
POSITION PRÉDÉTERMINÉE

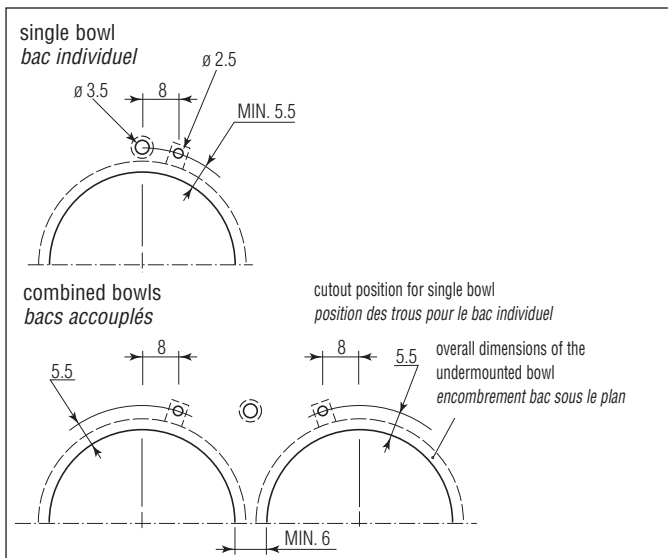

OPTIONAL POSITION
POSITION EN OPTION

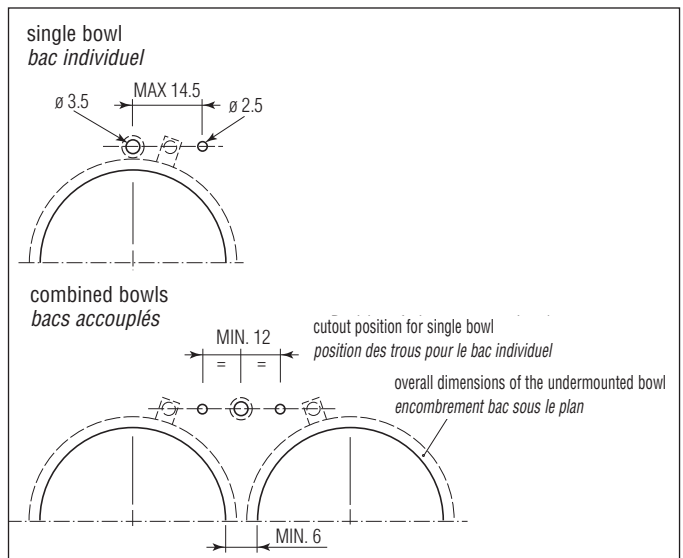

INSTALLATION

The bowls and the control knob must be installed under the countertop through the corresponding cutouts.

INSTALLATION

Le bac et la poignée de commande doivent être appliqués par en dessous le plan de travail à travers les trous d'encastrement.

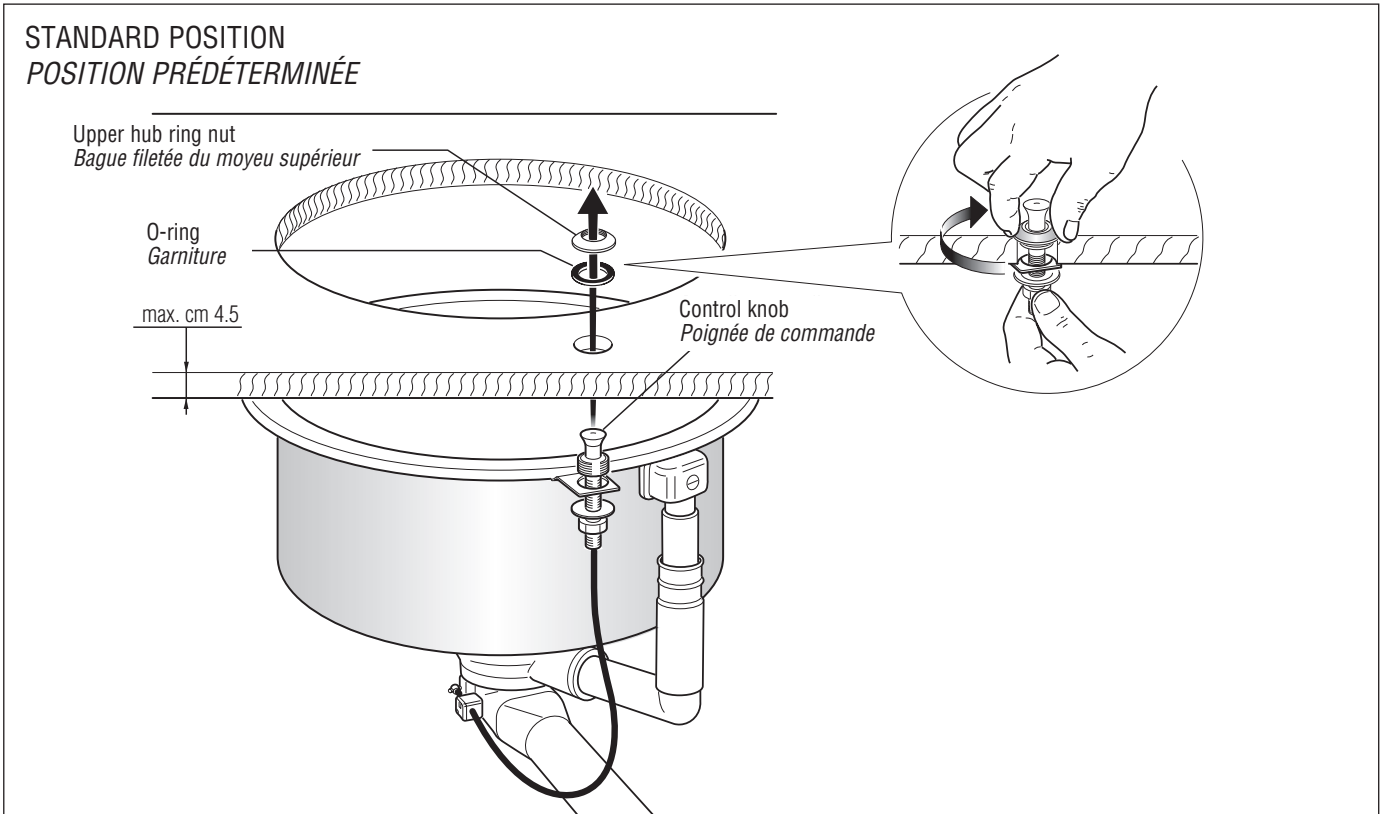

If necessary, the control knob can be positioned further away from the bowl's rim.

After removing the metal ring and the O-ring, slide out the control knob through the hole in the bowl and install it in the desired position on the countertop. Make sure that the cord is not taut.

Si nécessaire, il est possible mettre la poignée de commande plus loin par rapport au bord du bac.

Après avoir enlevé la bague filetée et la garniture, ôter la poignée de commande à travers le trou du bac et l'introduire dans le plan de travail dans la position désirée en faisant attention que la cordelette ne soit pas tendue.

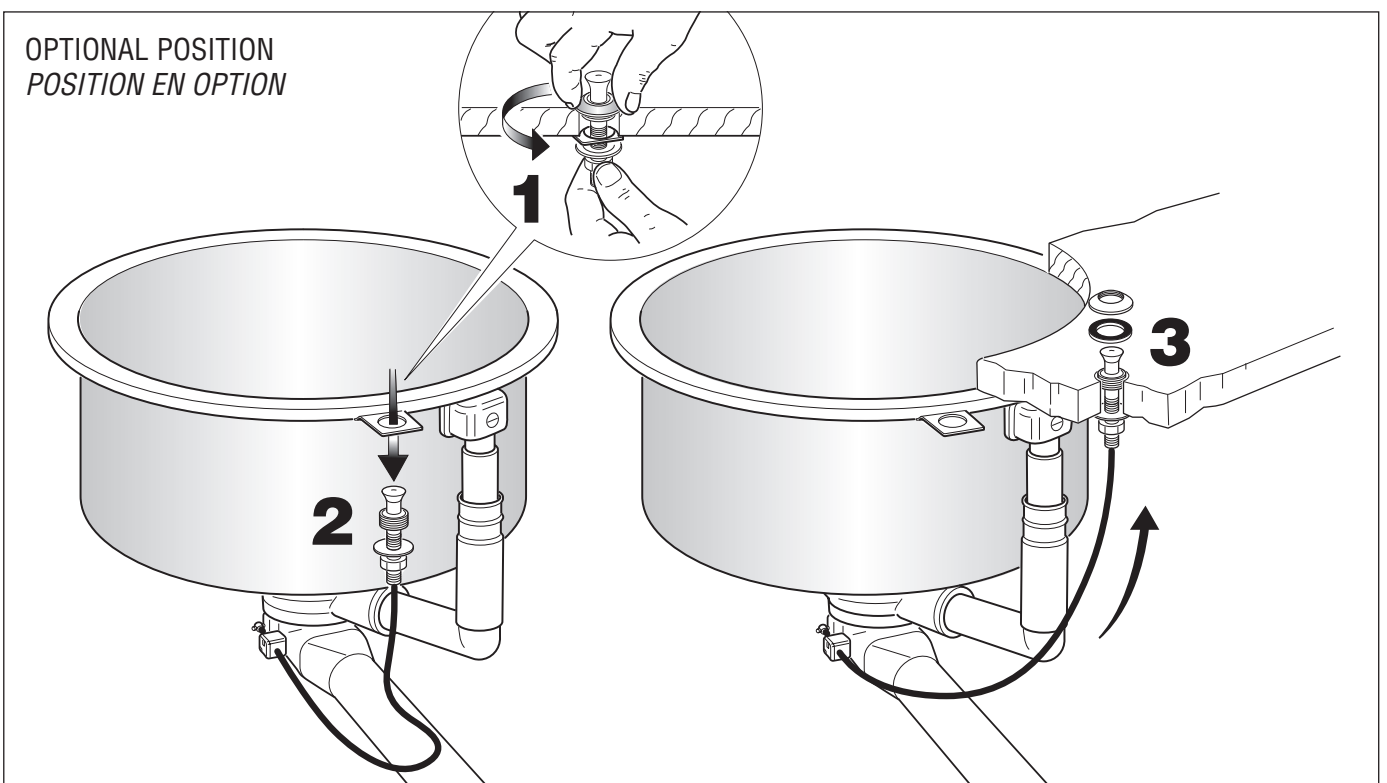

POSITION OF THE FASTENING ELEMENTS ON THE COUNTERTOP
POSITION DES ÉLÉMENTS DE FIXATION DANS LE PLAN DE TRAVAIL

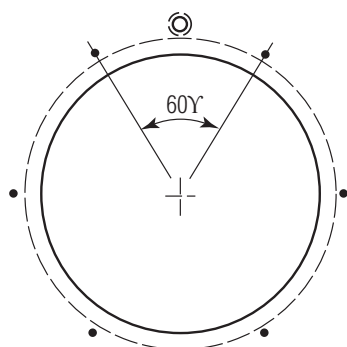

FASTENING TO THE COUNTERTOP (cm)
FIXATION AU PLAN DE TRAVAIL (cm)

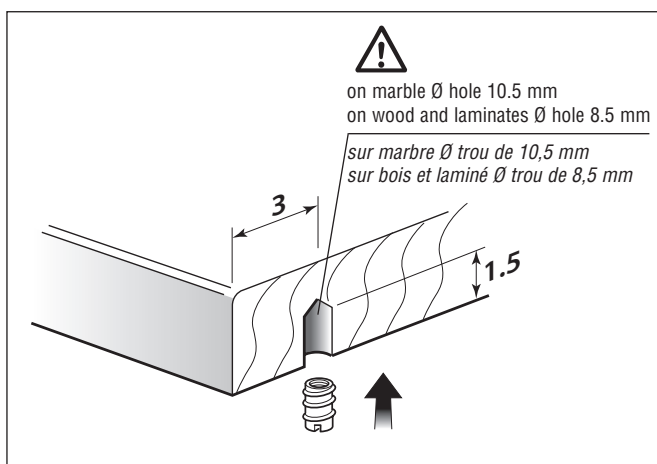

1. Make the holes for the bushes.
 In case of a marble countertop, inject a little adhesive into the hole to secure the bush.
 1. *Faire les trous pour les douilles.*
 Si le plan de travail est en marbre, injecter un peu de colle dans le trou pour fixer la douille.

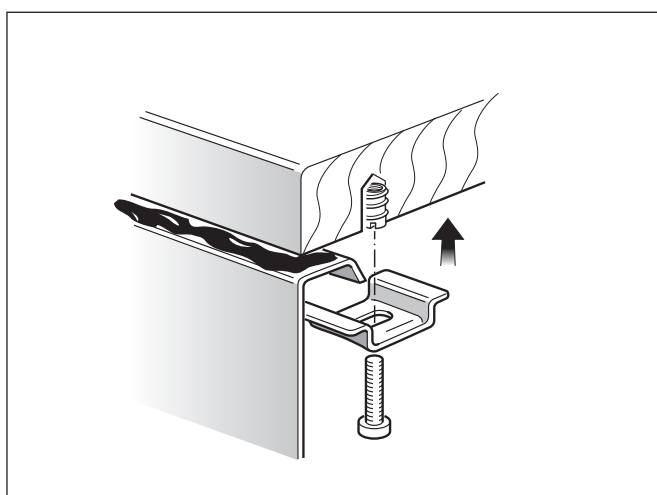

3. Fasten the bowl to the countertop using the special brackets.
 3. *Fixer le bac au plan de travail avec les pattes de fixation prévues à cet usage.*

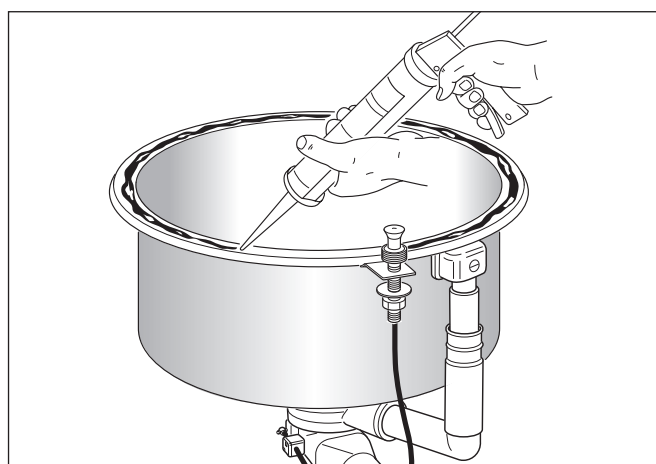

2. In order to avoid water infiltration, apply some sealant on the bowl's rim. Push the bowl against the underlying part of the countertop.
 2. *Pour éviter les infiltrations d'eau, appliquer du mastic sur le bord du bac. Presser le bac contre la partie du plan de travail située au-dessous.*

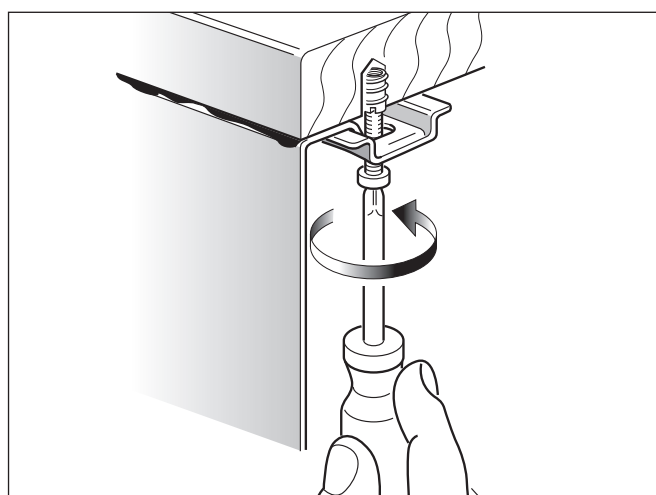

4. Tighten the brackets and remove any excess sealant.
 4. *Visser les pattes de fixation et enlever l'éventuel excédent de mastic.*

ALPES-INOX® s.r.l.

Via Monte Pertica, 5 - 36061 Bassano del Grappa (VI) Italia - Tel. +39 0424 513500 - www.alpesinox.com - info@alpesinox.com